



GENUINE ACCESSORIES

Installation Instructions

Part Number
0000-8D-N03

Cargo Tray

Applicable Vehicle
CX-9 2007 All models

Package Contents

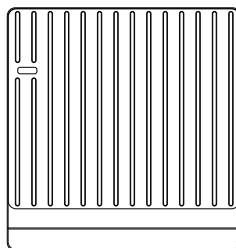
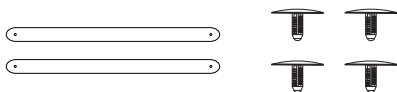
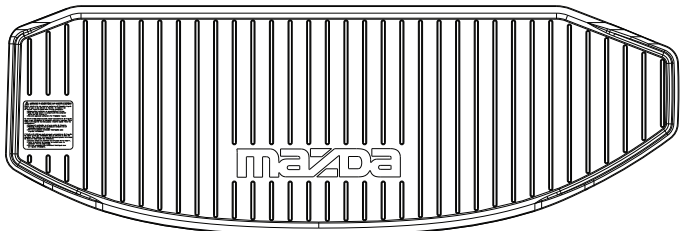

L

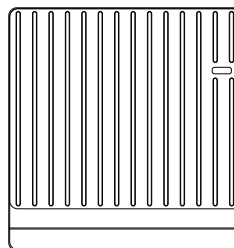

R

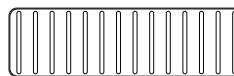
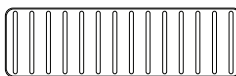

Tools Required



Drill Stop

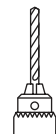

6 mm

0 Notes before installation

- Ensure the velcro strip is installed straight across the large cargo tray back before beginning.
- Because of the strength of the velcro it is required that you properly position the components before removing the tape liners and applying pressure to them.
- The velcro on the back of the components must have the liner pulled off before they can be applied.
- Cargo area should be dry and clear of debris before attempting installation.
- Large rear section is designed to accommodate power lift gate and non-power lift gate vehicles. Non-power lift gate will have a small area on the driver's side that the cargo liner will not cover.

1 Lower 3rd row seat and prepare drill bit with stopper.

2

25/64"
10mm

3 Adjust the large cargo tray on the center of the lowered third row seat back, ensuring the edge of the seat back and tray are lined up. Do not remove any velcro liners at this time, as the component will become extremely difficult to adjust once the velcro has adhered to the vehicle carpet.

Note: Be sure to thread the seat releases through the slot in the component before letting the component fall into place. Seat release straps should be centered in the slot.

4 Make sure the placement of the large cargo tray has not interfered with the seats ability to move up and down.

5 Peel back the component and remove the velcro liner from the long velcro strip.

Note: Do not completely remove cargo tray from the seat back, as the proper positioning could be lost.

6 Reposition the large cargo tray to the proper seat back position. ① Push down firmly in the area of the velcro to adhere to seat back. ② After velcro has contacted seat back, peel the leading edge of the cargo tray component back to expose the fastener holes.

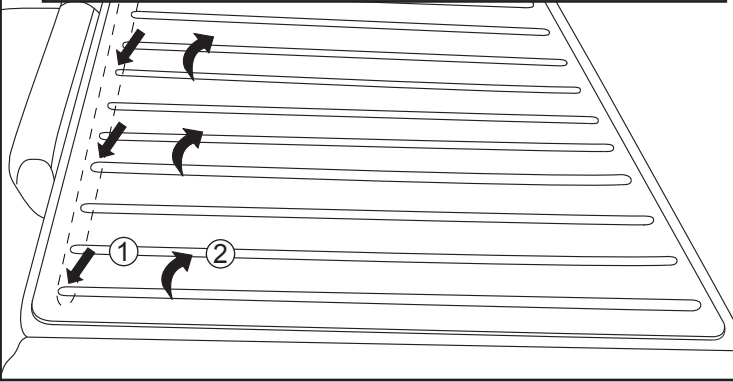

7 Align the drill with the holes on the velcro strip and drill two holes into the back of the seat.

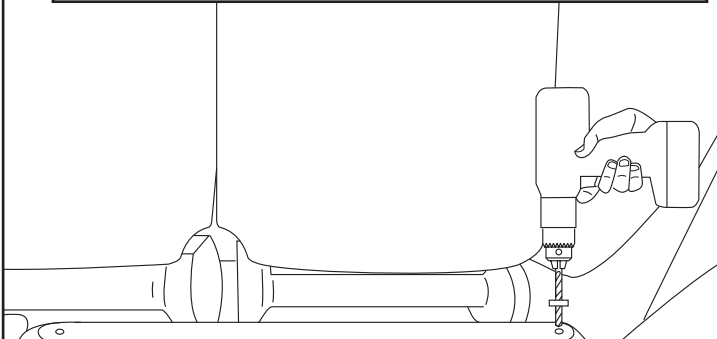

Warning: Failure to use a drill stop set at 10mm can cause damage to the seat front, requiring an expensive repair.

8 Place fasteners in holes and press to secure.

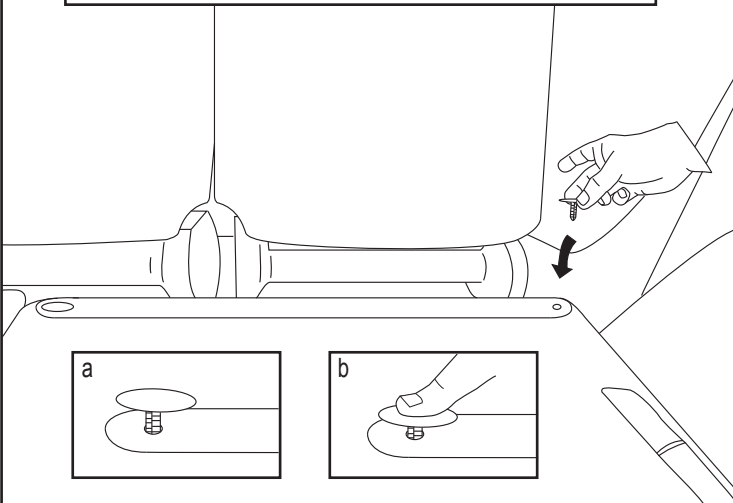

9 Fold the seat flap rearward and reposition the component. Thread the seat releases through the slot in the component before letting it fall into place. Be sure the seat release is centered in the slot.

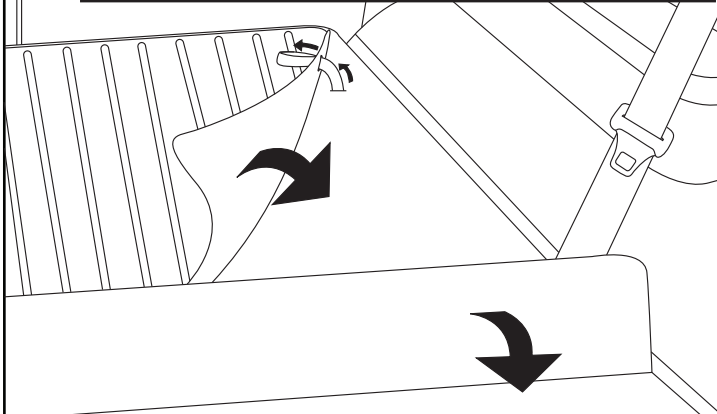

10 Reconfirm the cargo tray is not interfering with the seat operation. If interference is noted, reposition as required.

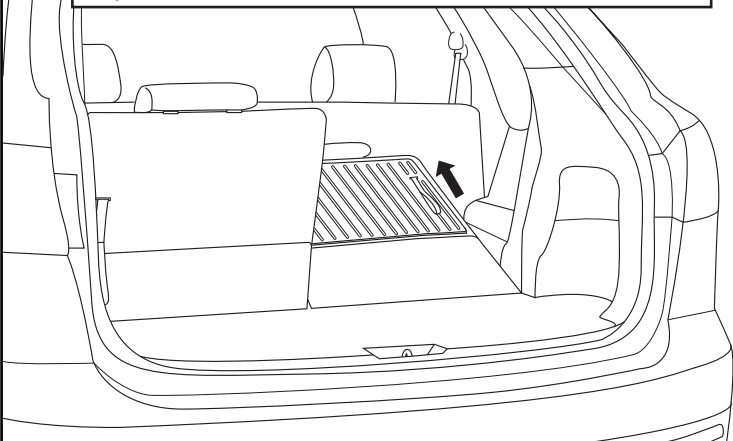

11 Position the small tray on the seat flap. The edge that has a slight bevel faces the front of the vehicle. Repeat steps 1-11 on opposite side.

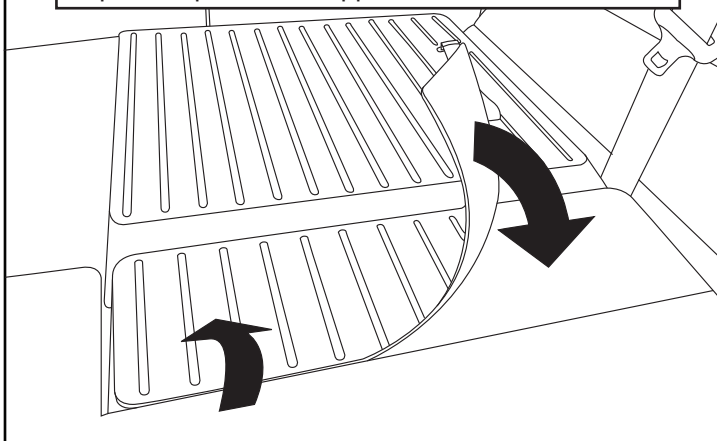

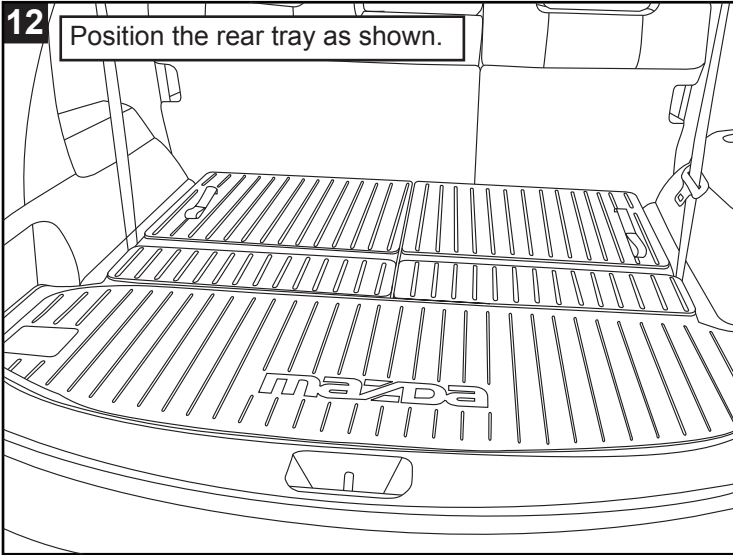

13 Adjust components as needed to ensure proper seating and fit.

14 If dealer installed be sure to provide these instructions to the vehicle owner.

Congratulations! You have completed the installation of your cargo tray.

Care and Cleaning

- Components can be cleaned with a variety of mild soaps or automotive cleaning products
- Rinse trays thoroughly with water and allow them to dry before reinstalling.

Usage Notes

Manufacturer will not be responsible for any damage to product or vehicle due to accident or misuse.

Your cargo tray is designed to transport normal cargo contents. Flammable or dangerous materials should not be transported in your vehicle at any time. If any corrosive chemicals are spilled on your cargo tray it should be cleaned as described in the Care and Cleaning section.

Large rear section is designed to accommodate power lift gate and non-power lift gate vehicles. Non-power lift gate will have a small area on the driver's side that the cargo liner will not cover.

WARNING
 Static electricity can cause an explosion of flammable liquid, vapor or gas in any vehicle or trailer. To reduce risk of serious injury when filling containers:

- Always place container on the ground before filling.
- Keep the nozzle in contact with the container while you are filling it.
- Use only approved containers for flammable liquid.

